

■ 线圈外观图

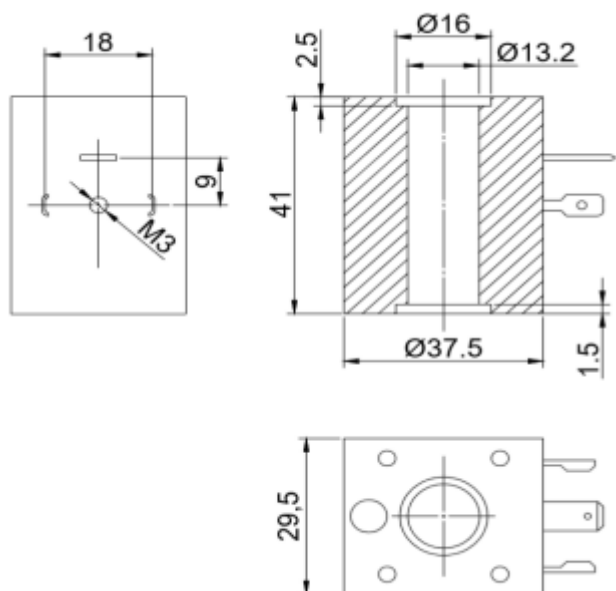

■ 线圈参数表

常规电压	AC220V AC110V DC24V DC12V	
常规功率	AC	9V 15VA 20VA
	DC	11W 12W 15W
其他特种电压、特种功率可定制		
绝缘等级	F、H	
线圈连接方式	DIN43650A	